

NOTES:

1. Remove all sharp edges and burrs.
2. All tubular work shall comply with AS1163 & AS1074.
3. All welding shall comply with AS/NZS1554.1 Category SP, using E41XX electrodes.
4. All parts to be galvanised after fabrication to AS/NZS4680.
5. All pipe threads shall comply with AS1722 - Part 2.
6. Install cable support after galvanising.
7. Weathercap to TC-1108.
Install weathercap after galvanising.
8. Bracket outreach - length as specified, up to 5.0 metres maximum for 10.5 kg luminaire or 4.5 metres maximum for 15 kg luminaire.
9. All dimensions are in millimeters
10. Bracket to comply with relevant power company standard requirements.
11. Dimensions are common to both single & double outreach brackets unless otherwise stated.
12. Unless otherwise specified, all steel shall be Steel Tube Grade 250 and Grade 350 for bracket arm.
13. All welds shall be 6mm fillet unless otherwise specified.
14. Completed bracket assembly shall be clearly labelled "Type 2".
15. See TC-1067 for detail of Stiffening Plate.

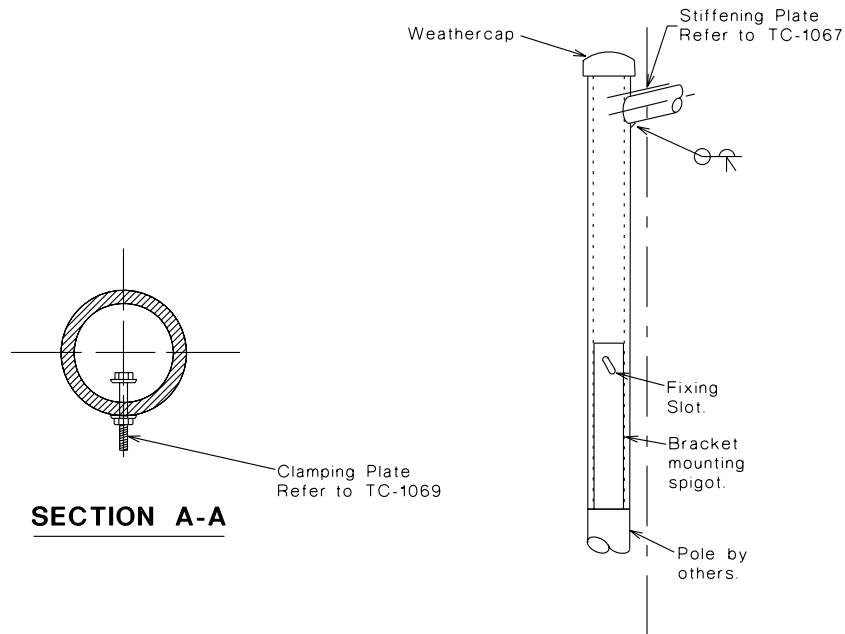
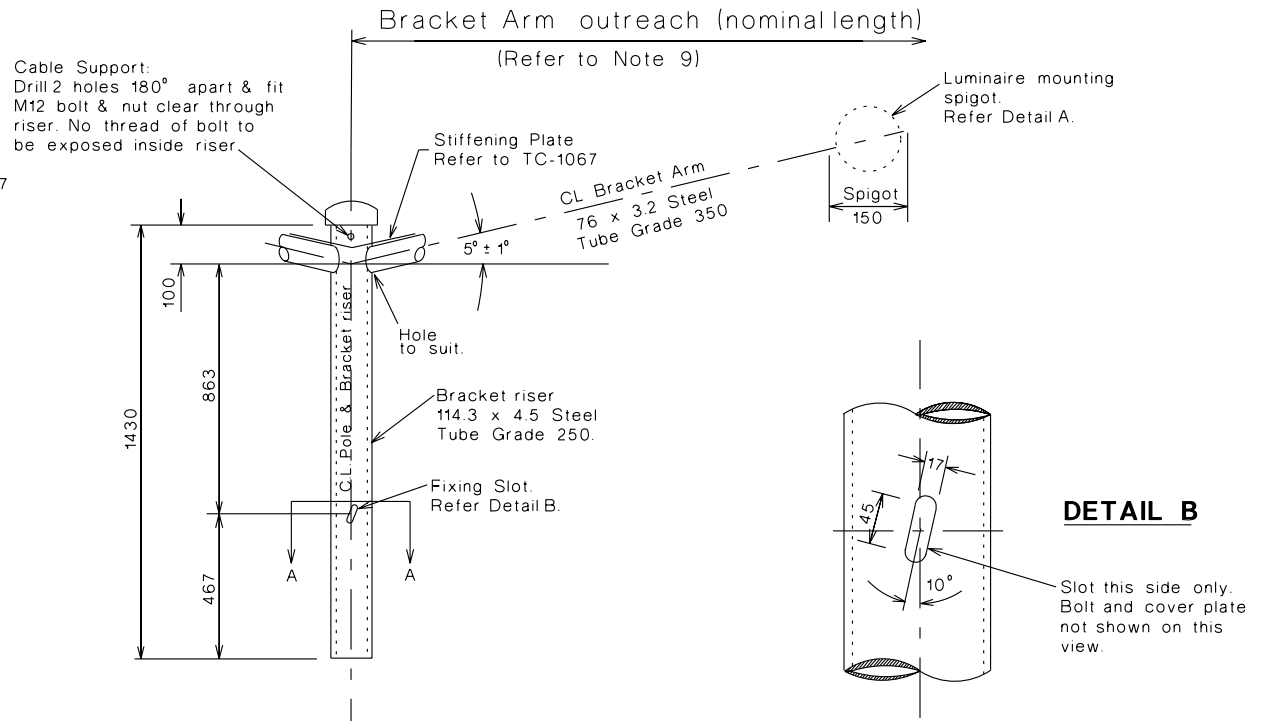
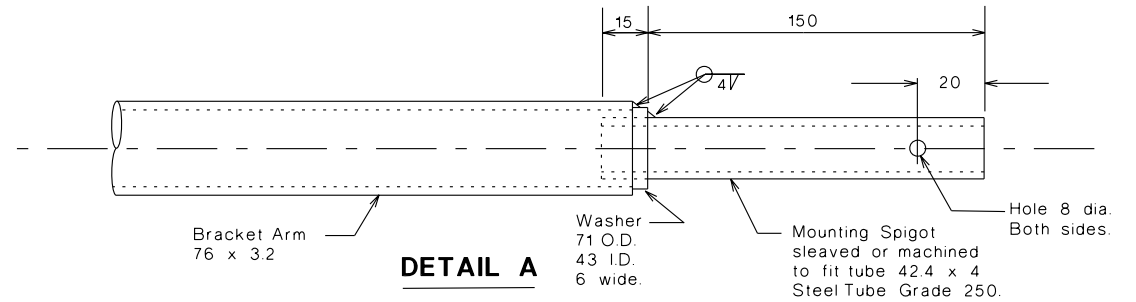

AMEND.	Appd.	DATE	AMENDMENTS
E			
D	SB	19/9/06	REFERENCE TO SEC DELETED
C	RS	6/01	AS/NZS STANDARDS UPDATED
B	RS	11/6/97	WELDS UPDATED
A	RS	4/6/97	STIFFENING PLATE ADDED

GENERAL NOTES / CROSS REFERENCES
UNSPECIFIED DIMENSIONS ARE IN mm.

ASSOCIATED DRAWINGS:
TC-1060, TC-1067, TC-1108,
TC-1069, TC-1070

vicroads

INTELLIGENT TRANSPORT
SYSTEMS GROUP

STANDARD DRAWING

STREET LIGHTING BRACKET SINGLE & DOUBLE - TYPE 2
UP TO 5m OUTREACH FOR 10.5 kg LUMINAIRE
UP TO 4.5m OUTREACH FOR 15 kg LUMINAIRE

CHECKED	DATE	APPROVED	DATE	SPEC. REF.	SHEET No.	DRAWING No.	AMENDMENT
R.S.	9/9/96	B. HEARN	11/9/96			TC-1061	D
		MANAGER	ITS				