

Heat Treatment for Item 1 Only:
Temper for 45 minutes minimum at 430° to 450°
before Pickling or Galvanising

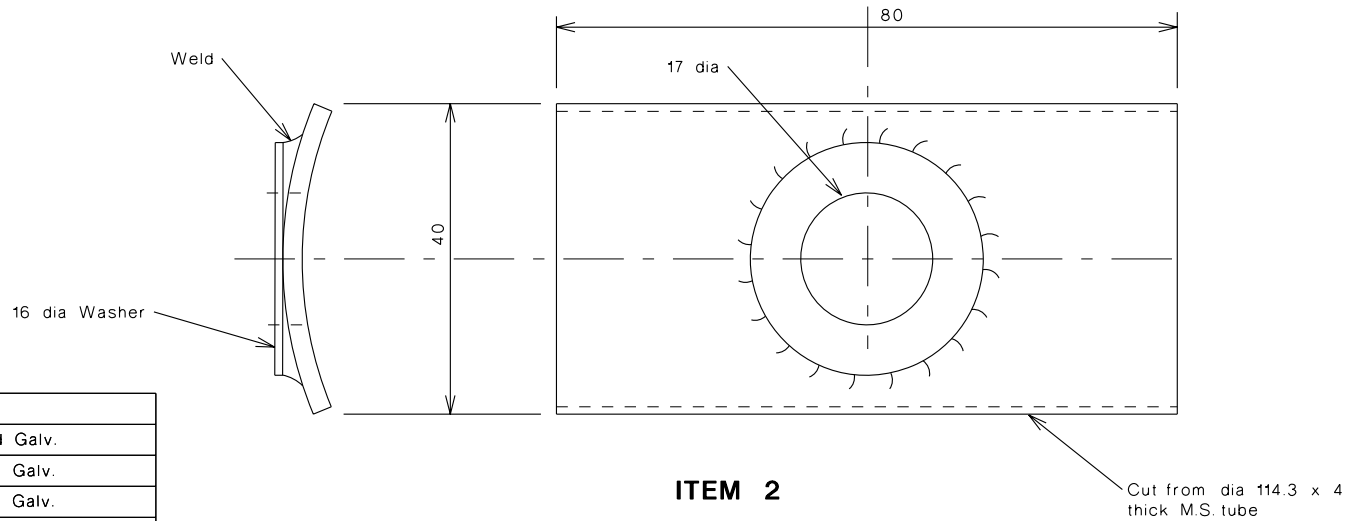

ITEM	DESCRIPTION	No. OFF	MATERIAL	REMARKS
4	16 dia Flat Washer	1	M.S	Galvanised
3	Nut, M16	1	M.S	Hot Dipped Galv.
2	External Clamping Plate	1	Steel	Hot Dipped Galv.
1	Internal Clamping Plate	1	Steel	Hot Dipped Galv.

AMEND.	Appd.	DATE	AMENDMENTS

GENERAL NOTES / CROSS REFERENCES
UNSPECIFIED DIMENSIONS ARE IN mm.

ASSOCIATED DRAWINGS:
TC-1060, TC-1061

vicroads

STANDARD DRAWING
STREET LIGHTING
CLAMPING PLATE - BRACKET TO POLE SPIGOT

INTELLIGENT TRANSPORT
SYSTEMS GROUP

CHECKED DATE
SP 18/9/06

APPROVED DATE
SB 19/9/06
MANAGER ITS

SPEC. REF. SHEET No. DRAWING No. AMENDMENT
TC-1069