

Certified By:

(BLOCK LETTERS)

(SIGNATURE)

(DATE)

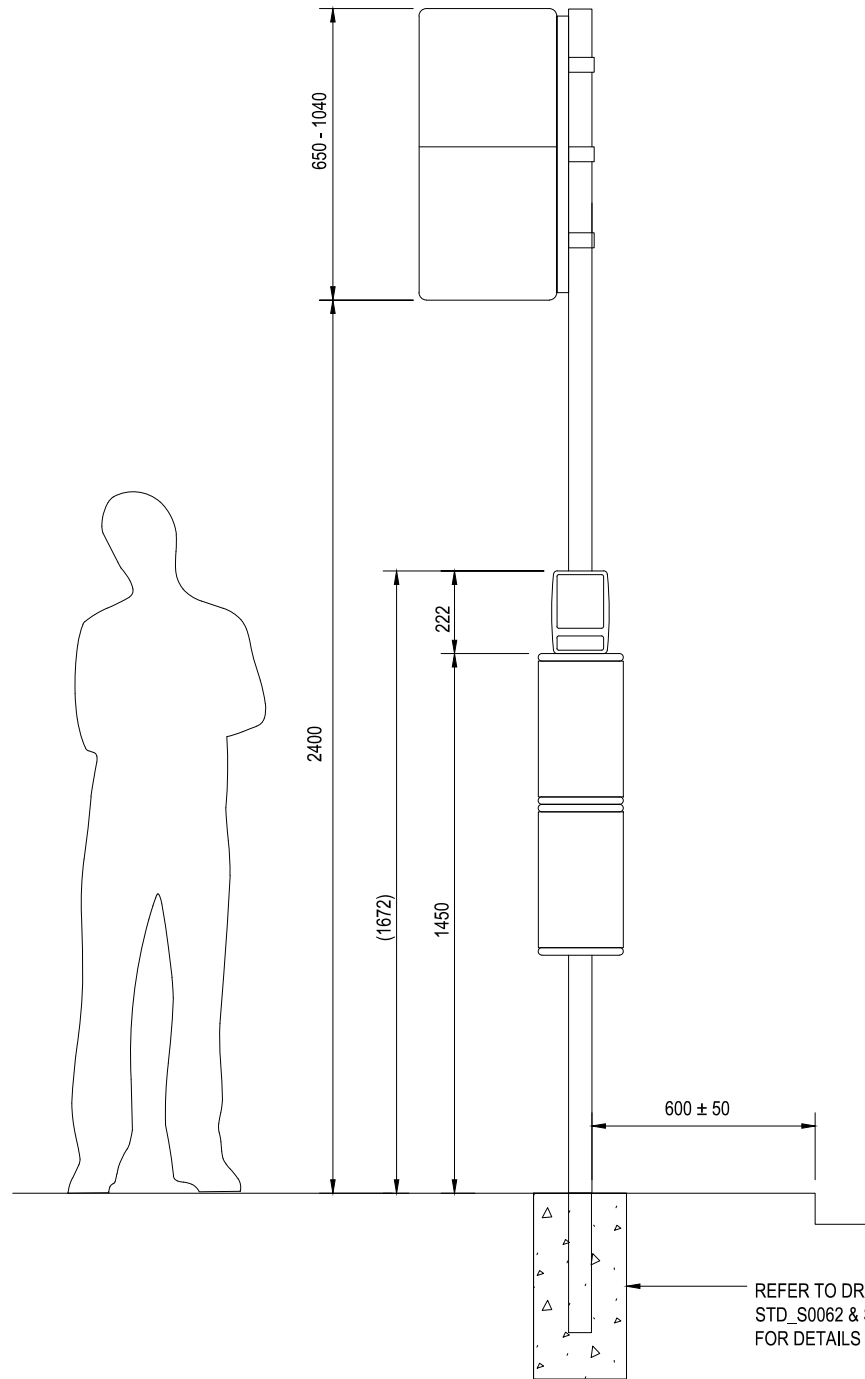

ELEVATION - SINGLE SIDED
SCALE 1 : 20

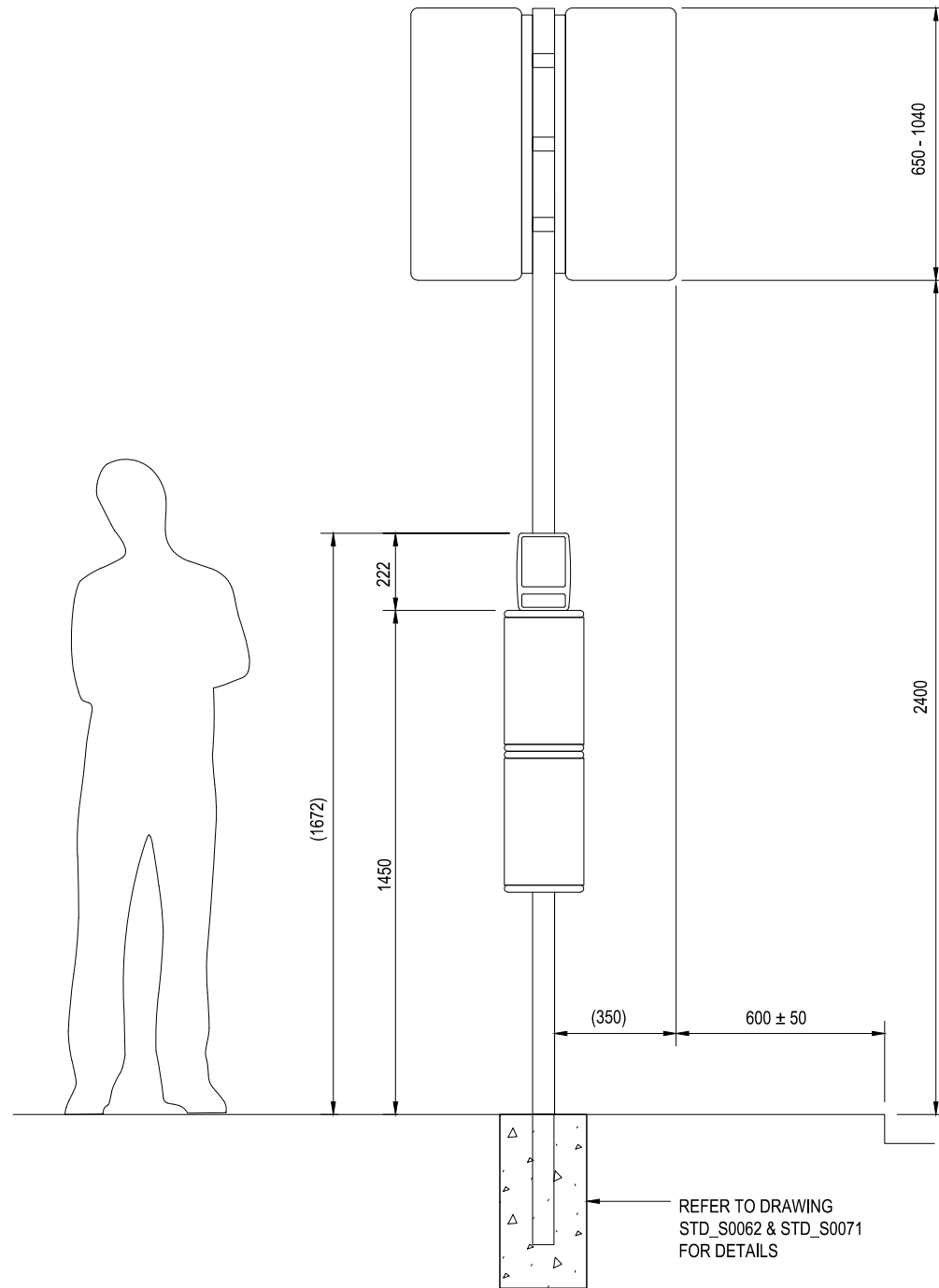

ELEVATION - DOUBLE SIDED
SCALE 1 : 20

IF MORE THAN 2 TIME TABLES ARE REQUIRED ADDITIONAL POLES ARE TO BE ADDED TO ALLOCATE FOR EXCESS TIMETABLES. APPROVAL FROM DOT IS REQUIRED FOR ADDITIONAL POLES

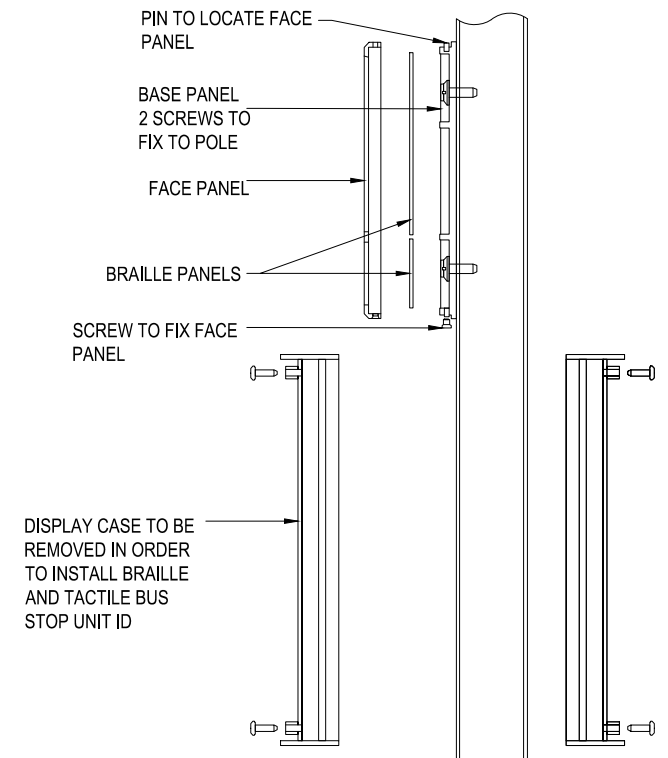

ASSEMBLY VIEW
NTS

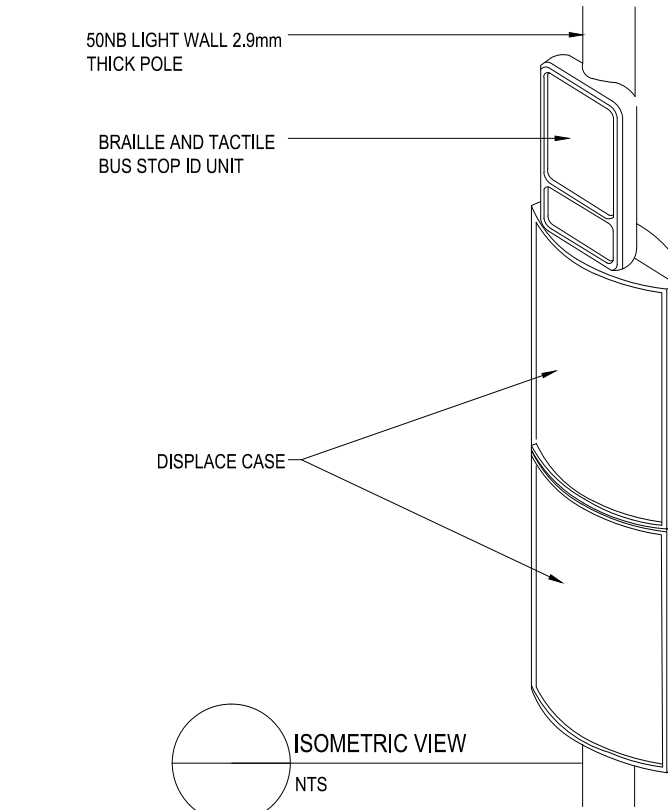

ISOMETRIC VIEW
NTS

NOTE: ALL DIMENSIONS ARE IN mm

| Revised By | In Serv | Rev. | Date | Description | Designed | Checked | Ind. Review | Approved |
|------------|---------|------|----------|--------------------------------|----------|---------|-------------|----------|
| TOMKINSON | | B | 11/10/21 | AMENDMENTS AS PER DOT COMMENTS | OB | JH | MM | JH |
| TOMKINSON | | A | 11/03/20 | AS SUBMITTED TO PTV | DK | JG | RQ | JG |

| | |
|---------------------|--|
| Consultant | |
| Franchisee / Lessee | |

This drawing has been prepared by, or compiled from information provided by, persons other than PTV. To the maximum extent permissible by law, PTV takes no responsibility for, and makes no representations in relation to, the completeness, accuracy or quality of any information contained in this drawing. Each user of this drawing releases PTV from all and any loss, damage, cost, expense or liability in relation to the use of, or any reliance on, this drawing or the information contained in it.

All written dimensions take precedence over scaled dimensions.

This drawing is provided only for the information of the person or organisation to whom PTV provides it. It may not be provided to, or used by, any other person without PTV's prior written consent.

| STRUCTURAL STANDARD DRAWING | | |
|--|---------------|-------|
| STANDARD BUS STOP DESIGN | | |
| SINGLE AND DOUBLE SIDED FLAG MOUNTED SIGN INSTALLATION SPECIFICATION | | |
| Up Location | Down Location | Datum |
| East . | East . | |
| North . | North . | |
| ID# . | ID# . | |

| | |
|-------------------------------------|--------------------|
| PUBLIC TRANSPORT VICTORIA PT | |
| File Name | STD_S0063_RevA.DWG |
| Sheet No. | 1 of 1 |
| In Serv. | |
| Scale | 1:25 |
| Sheet Size | A3 |

| | | | |
|----------------|-----------|---------------|----------|
| Drawn By | DK | Designed By | JG |
| Checked By | JG | Ind. Review | - |
| Approved | JG | Approval Date | 11/03/20 |
| Drawing Number | STD_S0063 | Revision | B |

23/07/19