

ISSUE	APPROVED BY	DATE	AMENDMENT
A	M-SSE	03/19	FORMATTING AND MINOR AMENDMENTS

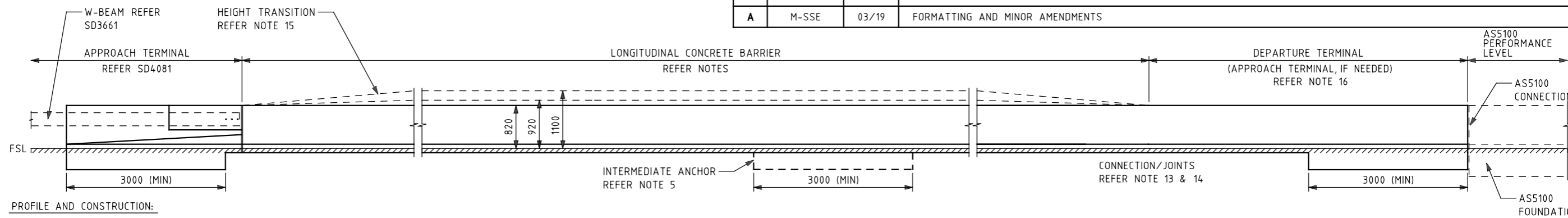

PROFILE AND CONSTRUCTION:

1. CONCRETE BARRIER PROFILE TO BE IN ACCORDANCE WITH SD3901. CONCRETE BARRIER CONSTRUCTION TO BE IN ACCORDANCE WITH SD3903 AND SD3904.

INSTALLATION DESIGN:

- CONCRETE BARRIERS MUST BE ADEQUATELY FIXED (ANCHORED) TO THE GROUND, ACCORDING TO TEST LEVEL, THEREFORE MUST BE DESIGNED AND INSTALLED ACCORDING TO SITE CONDITIONS. THE REQUIREMENTS OF THIS DRAWING MUST BE ADOPTED AND ALL SUBSTITUTIONS MUST BE EVALUATED AGAINST THIS DRAWING FOR EQUIVALENCY AND APPROVED BY VICROADS.
- CONCRETE BARRIERS MUST BE EMBEDDED IN ACCORDANCE WITH TABLE A WITHIN A DENSE GRADED ASPHALT PAVEMENT LAYER TO LATERALLY RESTRAIN THE BARRIER, AS SHOWN. OPEN GRADED ASPHALT PLACED ADJACENT TO THE BARRIER IS NOT CONSIDERED PART OF THE LATERAL RESTRAINT REQUIRED. LATERAL RESTRAINT MUST EXTEND FOR 1.5M EITHER SIDE OF THE BARRIER AS SHOWN.
- WHERE THE REQUIRED RESTRAINT (NOTE 3) CANNOT BE ACHIEVED THROUGH EMBEDMENT, AN EQUIVALENT RESTRAINT MUST BE DESIGNED AND APPROVED SUCH AS A REINFORCED FOOTING WITH FULL STRENGTH CONNECTION BETWEEN THE FOOTING AND BARRIER. BARRIERS MAY ALSO BE DOWELED TO A FOUNDATION AT 1000 C/C USING 28mm DIA. DOWELS (240mm LONG).
- A MINIMUM 3.0m LONG x 0.250m DEEP REINFORCED CONCRETE ANCHOR FOOTING MUST BE PROVIDED AT ALL BARRIER TERMINATIONS AND AT 48m MAXIMUM SPACING BETWEEN BARRIER TERMINATIONS (TABLE A), UNLESS THE BARRIER IS RESTRAINED BY OTHER MEANS SUCH AS PILES. END FOOTINGS MUST BE CAST MONOLITHICALLY WITH THE BARRIER.
- MINIMUM INSTALLATION LENGTH OF CONCRETE BARRIERS MUST BE IN ACCORDANCE WITH TABLE A (INCLUDING END ANCHOR FOOTINGS). WHERE THE MINIMUM LENGTH CANNOT BE ACHIEVED, THE BARRIER SYSTEM MUST HAVE SUFFICIENT STRENGTH TO RESIST THE LATERAL LOADS AT THE EFFECTIVE LOAD HEIGHT, SPECIFIED IN AS5100.2-DESIGN LOADS, FOR A DYNAMIC IMPACT.
- BARRIERS ERECTED ON A SUPERELEVATED ROADWAY SHALL CONFORM WITH THE REQUIREMENTS OF AUSTRROADS GUIDE TO ROAD DESIGN PART 6.
- CONCRETE BARRIER INSTALLATION MUST NOT DEVIATE FROM THE DESIGN ALIGNMENT BY MORE THAN ±20mm AT ANY POINT AND THE HEIGHT MUST NOT DEVIATE FROM THE DESIGN HEIGHT BY MORE THAN ±20mm AT ANY POINT. FOR PRECAST, THE SEPARATION BETWEEN ADJACENT BARRIER UNITS MUST BE 10mm ±5mm.
- CONCRETE BARRIERS MUST AVOID 'LOAD TRANSFER' INTO OBJECTS SUCH AS RETAINING WALLS AND BRIDGE PIERS. OTHERWISE, CONCRETE BARRIERS MUST BE PLACED ON STRUCTURALLY DESIGNED REINFORCED CONCRETE FOOTING/PILES, AND REQUIRE A FULL STRENGTH, MOMENT AND SHEAR CONNECTION WITH THE FOOTING IN ACCORDANCE WITH AS5100 AND VICROADS BRIDGE TECHNICAL NOTES.
- IN-FILL CAN BE PROVIDED BETWEEN CONCRETE BARRIERS AND CUT BATTERS FOR STRENGTH AND MAINTENANCE REASONS. BARRIER INSTALLATION DESIGN TO INCLUDE TYPE OF BACKFILL AND PROVISION FOR DRAINAGE.
- MEDIAN BARRIER FOR SPLIT LEVEL CARRIAGEWAYS, GREATER THAN 600mm, REQUIRE A SITE SPECIFIC INSTALLATION DESIGN IN ACCORDANCE WITH AS5100.

LIFTING:

12. AFTER BARRIER INSTALLATION, LIFTING ANCHORS RECESSES MUST BE FILLED WITH AN APPROVED POLYMER MODIFIED CEMENTITIOUS REPAIR MORTAR IN ACCORDANCE WITH SECTION 689 OF VICROADS SPECIFICATIONS.

CONNECTIONS AND TRANSITIONS:

- CONCRETE BARRIERS MUST HAVE CONNECTIONS/JOINTS AT 6000mm INTERVALS UNLESS SPECIFIED OR OTHERWISE APPROVED BY VICROADS.
- PRECAST CONCRETE BARRIERS MUST BE CONNECTED USING A PIN AND LOOP CONNECTION OR AN APPROVED ALTERNATIVE IN ACCORDANCE WITH SD3904. GAPS BETWEEN PERMANENT PRECAST CONCRETE BARRIER UNITS MUST BE GROUTED WITH A SUITABLE GROUTING MATERIAL AS SPECIFIED IN CLAUSE 610.33 OF VICROADS SPECIFICATION.
- BARRIER HEIGHT TRANSITIONS UP OR DOWN MUST OCCUR AT A RATE NOT EXCEEDING 15H:1V. TRANSITIONS BETWEEN BARRIERS OF A DIFFERENT SHAPE MUST BE APPROVED PRIOR TO USE, BY VICROADS, AND MUST PROVIDE SMOOTH REDIRECTION AND PREVENT SNAGGING OR RAMPING. BARRIER TRANSITIONS TYPICALLY OCCUR OVER A 6m UNIT LENGTH.

END TREATMENTS:

16. CONCRETE BARRIER TERMINATIONS THAT CAN BE IMPACTED SHOULD BE CRASHWORTHY USING AN ACCEPTED SAFETY PRODUCT SUCH AS A CRASH CUSHION OR AN APPROVED BARRIER TRANSITION (e.g. SD4081).

BRIDGES:

- PERFORMANCE LEVEL BARRIERS MUST BE DESIGNED TO FULLY COMPLY WITH THE REQUIREMENTS OF AS5100 IRRESPECTIVE OF THESE DRAWINGS.
- FOR THE DESIGN OF PERFORMANCE LEVEL BARRIERS, NO CONSIDERATION SHALL BE MADE OF TEST LEVELS OR THE IMPLIED EQUIVALENCY OF TEST LEVELS TO PERFORMANCE LEVELS THAT IS GIVEN IN TABLE 14.4 OF AS5100.1, AS PER BRIDGE TECHNICAL NOTE BTN001.

BARRIER ELEVATION INSTALLATION LAYOUT (TYPICAL)
(NOT TO SCALE)

TABLE A: BARRIER TEST LEVEL & ANCHORAGE

TEST LEVEL	BARRIER HEIGHT (H)	MINIMUM LENGTH (INC. TERMINALS)	MAX ANCHOR SPACING	EMBEDMENT DEPTH (D)
TL-3 MASH	820	48m	48m	75mm (MIN)
TL-4 MASH	920	48m	48m	75mm (MIN)
TL-5 MASH	1100	66m	24m	100mm (MIN)

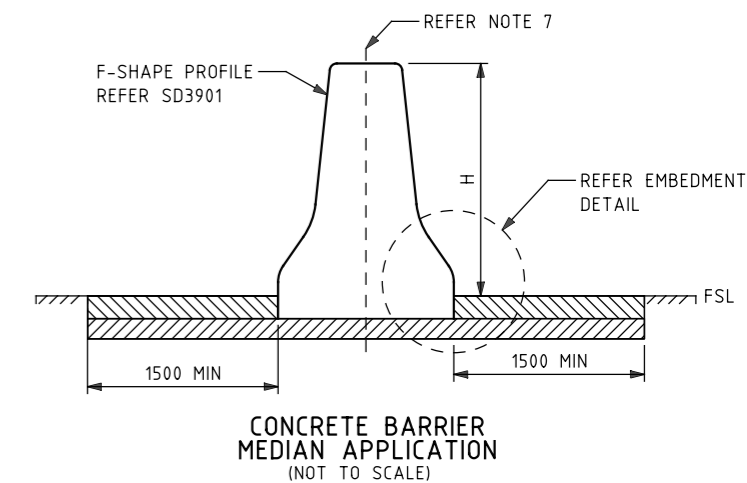

CONCRETE BARRIER MEDIAN APPLICATION
(NOT TO SCALE)

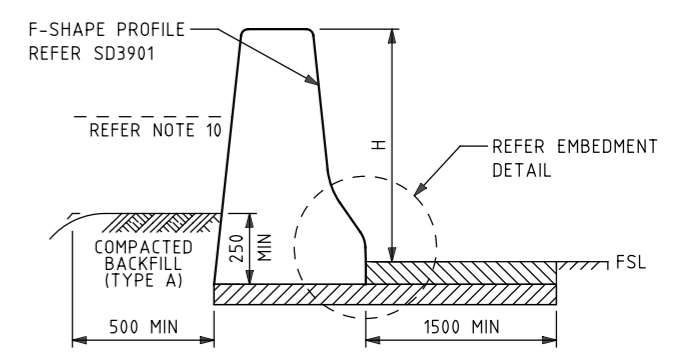

CONCRETE BARRIER VERGE APPLICATION
(NOT TO SCALE)

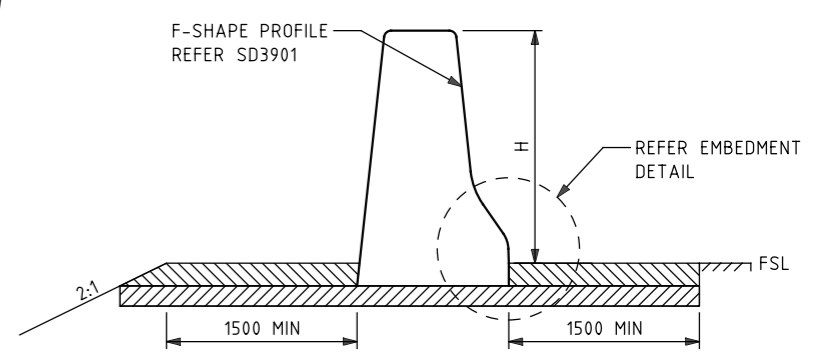

CONCRETE BARRIER VERGE APPLICATION
(NOT TO SCALE)

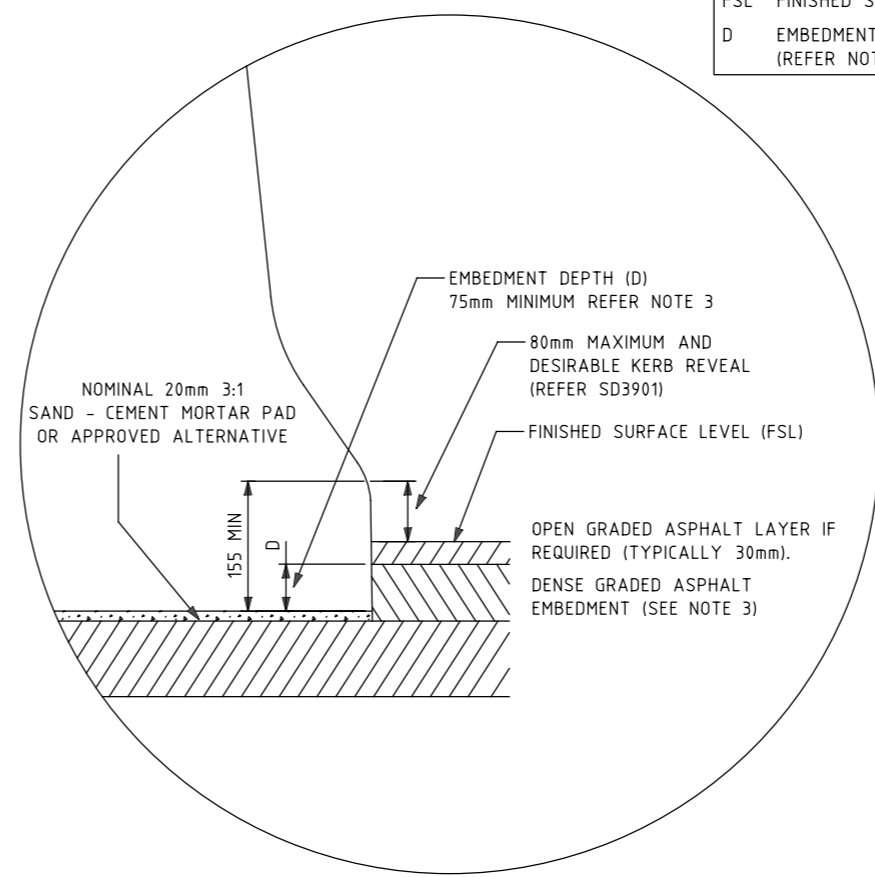

EMBEDMENT DETAILS - ELEVATION

REFERENCES AND NOTES:
1. ALL DIMENSIONS ARE IN MILLIMETERS UNLESS SHOWN OTHERWISE.

DISCLAIMER
THIS DRAWING DOES NOT COVER PERFORMANCE LEVEL BARRIERS WHICH SHALL BE DESIGNED TO FULLY COMPLY WITH THE REQUIREMENTS OF AS5100 IRRESPECTIVE OF THESE DRAWINGS

ROAD AND TRAFFIC DESIGN
MANAGER SAFE SYSTEM ENGINEERING
60 DENMARK STREET
KEW VICTORIA 3101
PHONE (03) 9854 2666



ROAD SAFETY BARRIERS
CONCRETE BARRIERS - F-SHAPE INSTALLATION

NOT TO SCALE
APPROVED M-SSE
02/2019
SD NO. SD3902
ISSUE A

VicRoads Drawing No. 720418